



MAGIX PRECISE MACHINERY(KUNSHAN) CO.,LTD

Address: No.99,CHANGSHUN ROAD,ZHANGPU TOWN,KUNSHAN CITY,CHINA

TEL: 86-512-57458871

FAX: 86-512-57458873

Test Report



Project NO. : 21MD09-014

Edit Date : Sept.24. 2021

Applicant : Sales Dep. MAGIX(KUNSHAN)

Address : 99 ChangShun Road,Zhangpu Town
Kunshan City China.

Product : Handlebar+Stem

Model No. : CHB-A6159 W:625 mm
CQS-JDST6358N-8/5 E:90mm L:250

Test Reference : EN15194:2017 (E)

Abstract of Result : Details as in test report.

TEST RESULT : PASS.

Remark: (1) Products sent by applicant have been tested by our laboratory The test result is included in this report.

(2) This test report is responsible for test samples only, not for the use of suit.

(3) This report contains (9) pages, it can not be abstracted and copied separately

项东武

杨涛

Approved _____

Checked by _____

Test Reference: EN15194: 2017 (E) 4.3.6.6.1.3

H/B+ Stem assembly-lateral bending test

1. Test Method:

For stems which have a quill for insertion into a fork-stem, clamp the quill securely in a fixture to the minimum insertion depth, or for stem extensions which clamp directly on to an extended fork-stem attach the extension to a fork-stem according to the manufacturer's instructions and clamp this fork-stem securely in a fixture to the appropriate height. Apply a force of 800N (accurate to within $0/\pm 5\%$) at a distance of 50 mm from the free end of the handlebar. Maintain this force for 1 min.

Key

- a) Combined stem and quill
- b) Stem extension
- 1 Minimum insertion depth
- 2 Clamping block
- 3 Solid steel bar

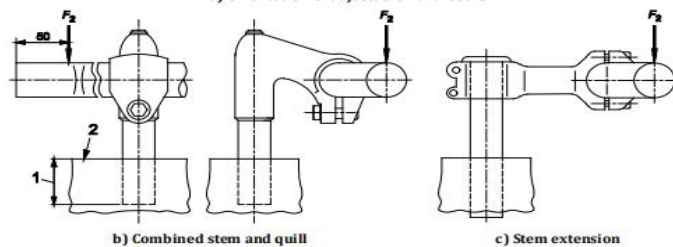

2. Test Requirement:

There shall be no cracking or fracture of the handlebar 、stem or clamp-bolt and the permanent set measured at the point of application of test force shall not exceed 15 mm.

3. Test Results:

1. Product: Handlebar+ Stem

2. Model No: CHB-A6159N W:625 mm.

CQS-JDST6358N E:90 mm. L:250

3. Static test: acting-force:800N. Acting force place:50mm away from handle bar end lasting time:1 min

4. Pass : permanent deformation < 15mm, test based on said no crack or fracture incurred fur stem

4. Appendix: Static test picture



5. Appendix: Static test picture

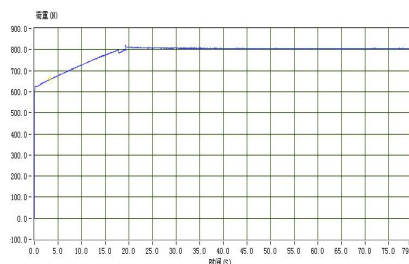



MAGIX PRECISE MACHINERY(KUNSHAN) CO.,LTD

Address: No.99,CHANGSHUN ROAD,ZHANGPU TOWN,KUNSHAN CITY,CHINA

TEL: 86-512-57458871

FAX: 86-512-57458873

Project NO: 20MD09-014

Test Referenc: **EN15194: 2017 (E) 4.3.6.6.2.2(3)**

H/B+ Stem forward bending test

1. Test Method:

Stage 1 : Apply a force of 1600N through the handlebar attachment point in a downward direction and at 45° to the axis of the quill or steel bar, and maintain this force for 1 min. Release the test force and measure any permanent set.

Key

- a) Stem extension
- b) Combined stem and quill
- 1 Clamping fixture
- 2 Solid steel bar
- 3 Applied force
- 4 Minimum insertion depth

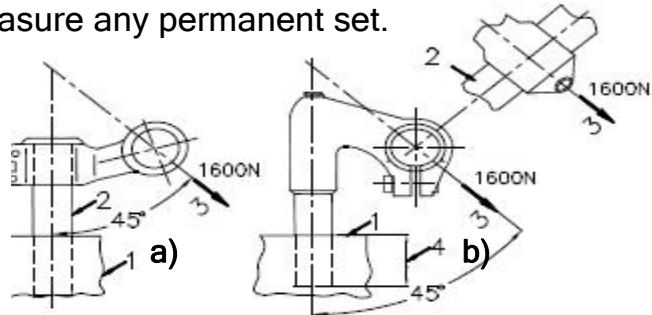

Stage 2 : With the handlebar-stem mounted as in stage 1, apply a progressively increasing force in the same position and direction as above figure until either the force reaches a maximum of 2600N or until the handlebar-stem deflects 50 mm measure at the point of the test force and in the direction of test force. If the stem does not yield or continue to yield, maintain the force for 1 min.

2. Test Requirement:

1. There shall be not visible cracks or fractures and the permanent set measured at the point of application of the test force and in the direction of the force shall not exceed 10 mm.

3. Test Results:

1. Product: Stem
2. Model No. CQS-JDST6358N E:90 mm. L:250
3. Static test: first phase:1600N. second phase: $\geq 2600N$.
4. Pass : no crack or fractures incurred in the applying-force direction .permanent deformation 10mm implement second phase' test by way of the same device, max force $\geq 2600N$

4. Appendix: Static test picture:



5. Appendix: Static test picture:

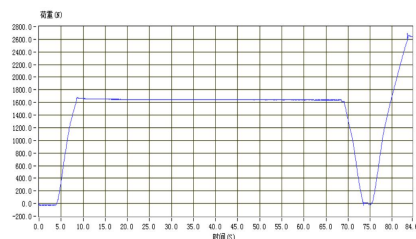



MAGIX PRECISE MACHINERY(KUNSHAN) CO.,LTD

Address: No.99,CHANGSHUN ROAD,ZHANGPU TOWN,KUNSHAN CITY,CHINA

TEL: 86-512-57458871

FAX: 86-512-57458873

Project NO:21MD09-014

Test Reference: **EN15194: 2017 (E) 4.3.6.6.3.2**

H/B + Barend + stem Torsional security test

1. Test Method:

Clamp the handlebar stem security in a fixture to the minimum insertion depth and with its axis vertical. Apply a torque of 70 Nm(accurate to within $0/\pm 5\%$) about the center-line of the stem-clamp. Divide the torque equally by vertically, downward forces applied to both sides of the handlebar and maintain the force for 1 min.

Key

- 1 Minimum insertion depth
- 2 Clamping fixture

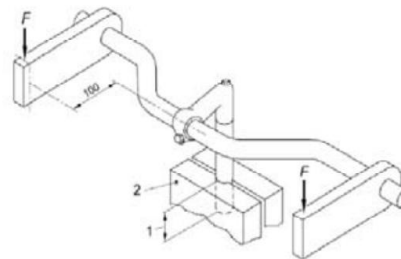

2. Test Requirement:

There shall be no movement of the handlebar relative to the handlebar-stem.

3. Test Results:

1. Product: Handlebar + Stem

2. Model No: CHB-A6159N W:625 mm.

CQS-JDST6358N E:90 mm. L:250

3. Static test: apply 70Nm in the center of stem's clamp, average the force perpendicularly, apply downwards on the 2 sides of handlebar, lasting 1 min. (Torque=force*the arm of force)

4. Pass : no displacement between stem and handle bar during testing.

4. Appendix: Static test picture:

5. Appendix: Static test picture:

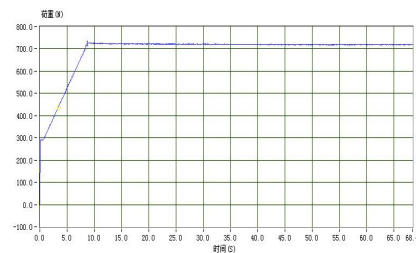

Test Reference: EN15194: 2017 (E) 4.3.6.7
H/B + stem fatigue test

1.Equipments:

Model's group type dynamic testing machine of bicycle.

2. Test Method:

1. Endurance test out of phase:

First, Mount stem to handlebar emending degree to 90° between the grip and stem quill unless the handlebar is connected with the stem forever, Handlebar and stem are fixed tightly to the mini-insertion apply $F \pm 220N$ force to the position at the distance of 50mm,at the end of handlebar, lasting 100,000 cycle times, take advantage of the out-of-phase test on the each of handlebar at the utmost frequency of 10Hz, referring to the drawing below.

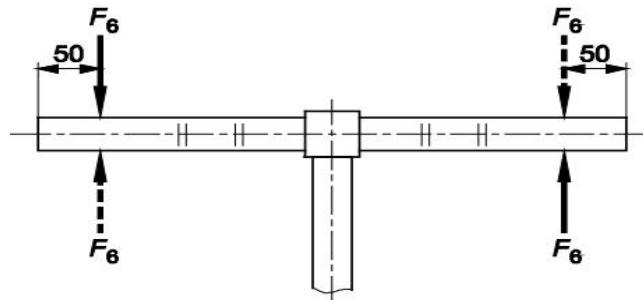

2. Endurance test in phase:

After completing in phase test for handlebar, disassembling the both sides of handlebar, then implement endurance test in phase with the same assembling way fixing pedestal. The applied cycling force is $F \pm 280N$, lasting 100,000 cycle times take advantage of in-phase test on the each of handlebar at the utmost frequency of 10Hz, drawing as follows.

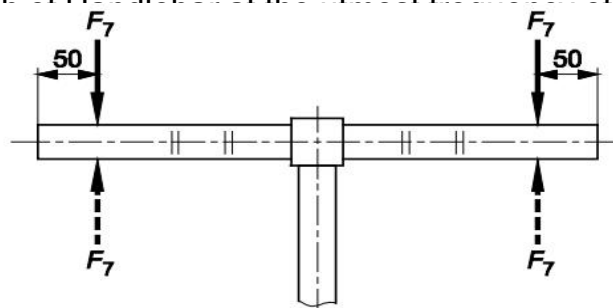

3.Test Requirement:

- 1.During test the required cycle frequency count for required test forces, it is stood without break or visible crack.
2. The handlebar must not break and have no visible cracks.



MAGIX PRECISE MACHINERY(KUNSHAN) CO.,LTD

Address: No.99,CHANGSHUN ROAD,ZHANGPU TOWN,KUNSHAN CITY,CHINA

TEL: 86-512-57458871

FAX: 86-512-57458873

Project NO:21MD09-014

4.Test Results:

1.Product: Handlebars, Hand Stems.

2.Model No: CHB-A6159N W:625 mm.

CQS-JDST6358N E:90 mm. L:250

3. Dynamic test: out phase, 3HZ, $F=\pm 220N$, NO1=100,100 cycle, NO2=100,101 cycle;
in phase ,3HZ, $F=\pm 280N$, NO1=100,100 cycle, NO2=100,101cycle.

4. Pass: During the testing no visible break or crack occur.

5.Appendix:

1.Test samples:



6.Test dynamically:



(Out phase)



(In phase)

7.Appendix: To reference behind page. (The dynamic test diagrammatic curve)



Test Reference: **EN15194: 2017 (E) 4.3.6.6.4.2**

H/B+ stem + fork stem torsional security test

1. Test Method:

Assemble the fork-stem correctly in the frame and attach the handlebar-stem to the fork

-stem with the locking system tightened in accordance with the manufacturer's instructions, and apply a torque of 40 Nm(accurate to within $0/\pm 5\%$) once in each direction of possible rotation in a plane perpendicular to the axis of the fork/handlebar-stem. Maintain each torque for 1min.

Legend

- 1 all frame and fork
- 2 steel rod full

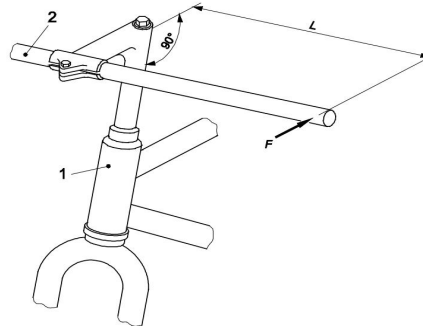

2. Test Requirement:

There shall be no movement of the handlebar-stem relative to the fork-stem.

3. Test Results:

- 1. Product: Stem
- 2. Model No.CQS-JDST6358N E:90 mm. L:250
- 3. Static test: acting-torque: 50Nm. acting plane: plane perpendicular to the stem's shaft forks, lasting time: 1 min (Torque=force*the arm of force).
- 4. **Pass: no displace between stem and fork-stem during testing.**

4. Appendix: Static test picture:





友森精密机械有限公司

MAGIX PRECISE MACHINERY(KUNSHAN) CO.,LTD

- | | |
|---|--------------------------------------|
| 1. 试验批号 Project NO: <u>21MD09-014</u> | 2. 试验日期 Test date: <u>2021-09-24</u> |
| 3. 产品名称 Product : <u>Handlebar+Stem</u> | 4. 试验时间 Test time: <u>08:10:13</u> |
| 5. 产品代号 Model No : <u>CHB-A6159+CQS-JDST6358N</u> | 7. 试验频率 Frequency : <u>3 HZ</u> |
| 6. 测试依据 Test Reference : <u>EN15194: 2017</u> | 9 力量 Force : <u>±220 N</u> |
| 8. 试验次数 Setting cycle : <u>100,100</u> | 11. 试验者 Tester <u>杨涛</u> |
| 10 机器型号 Test equipment: <u>CX-8129</u> | |
| 12. 备注 Remark: | |

Out phase test

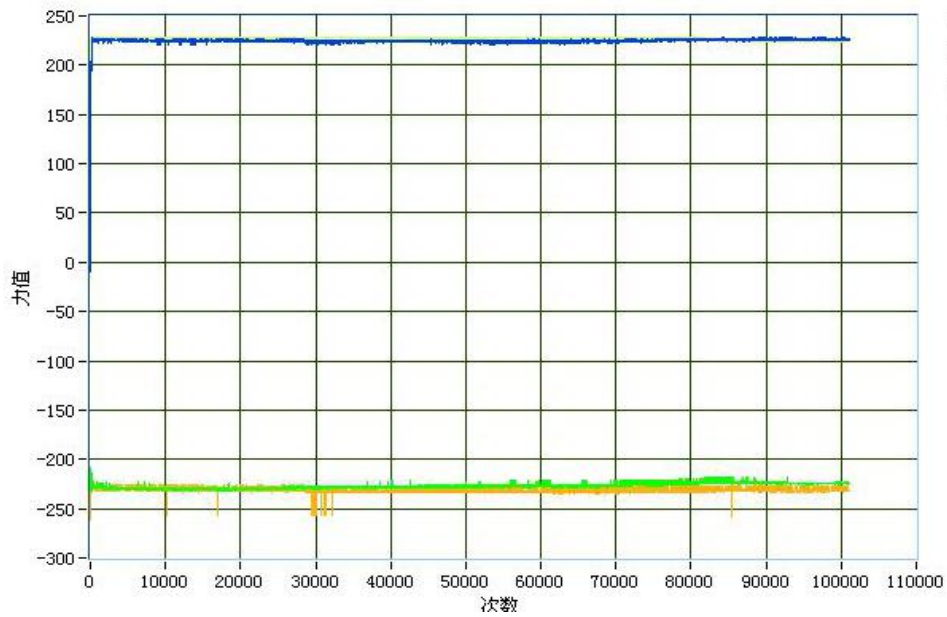

NO1 : 100,100 cycle no visible cracks.



友森精密机械有限公司

MAGIX PRECISE MACHINERY(KUNSHAN) CO.,LTD

- | | |
|--|--------------------------------------|
| 1. 试验批号 Project NO: <u>21MD09-014</u> | 2. 试验日期 Test date: <u>2021-09-24</u> |
| 3. 产品名称 Product : <u>Handlebar+Stem</u> | 4. 试验时间 Test time: <u>20:08:17</u> |
| 5. 产品代号 Model No: <u>CHB-A6159+CQS-JDST6358N</u> | |
| 6. 测试依据 Test Reference <u>EN15194: 2017</u> | 7. 试验频率 Frequency : <u>3HZ</u> |
| 8. 试验次数 Setting cycle : <u>100,101</u> | 9 力量 Force : <u>±280N</u> |
| 10 机器型号 Test equipment: <u>CX-8129</u> | 11. 试验者 Tester <u>杨涛</u> |
| 12. 备注 Remark: | |

In phase test

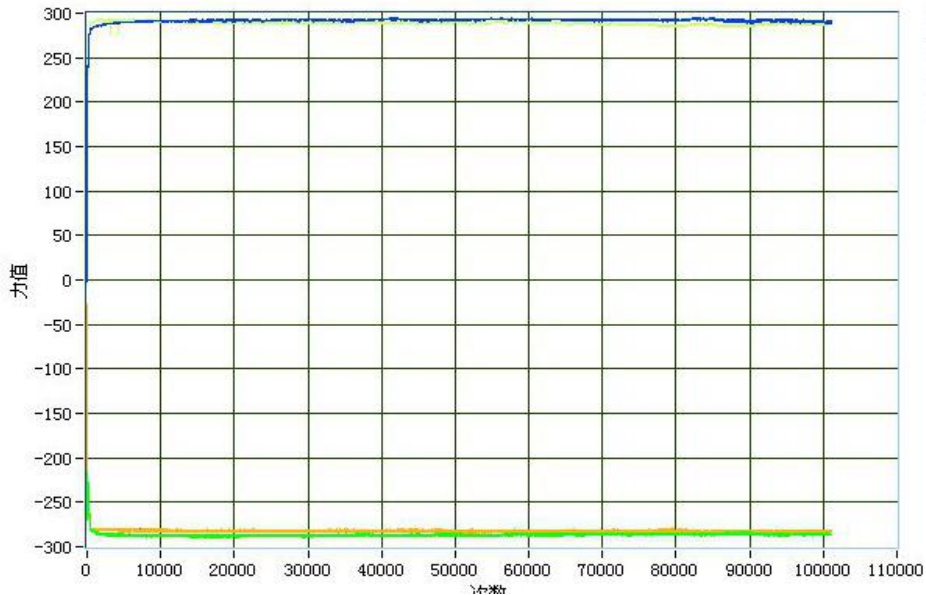

NO1 : 100,100 cycle no visible cracks.